

TRAIL ROOKIE

Trailparcours by G. Puschitz

Westernman.at



REINTAL RANCH

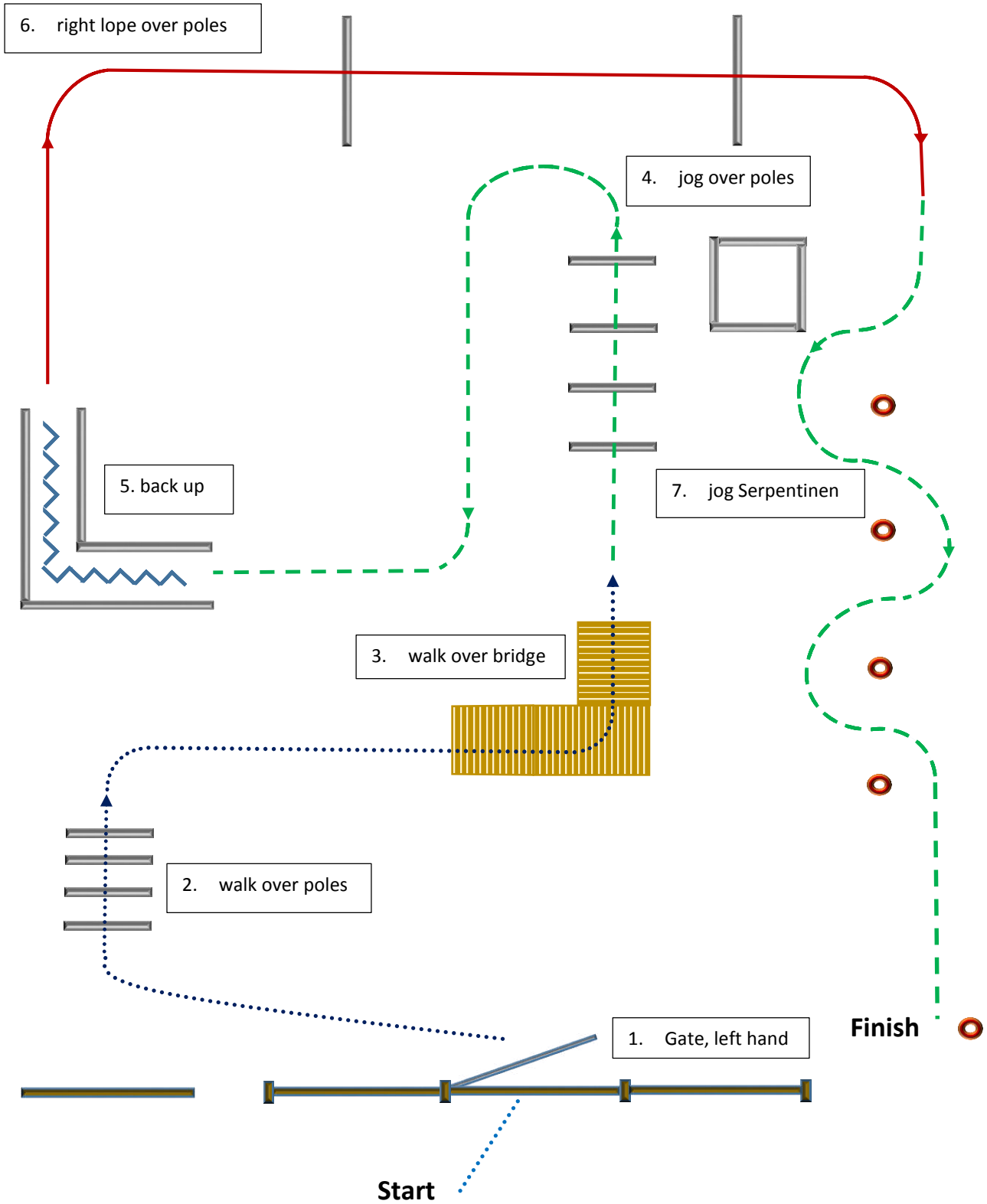

Walk/Schritt	Jog/Trab	Lope/Galopp	Back up/Rückwärts	Sidepass/Seitwärts	Galoppwechsel	Marker	erhöhte Stange
.....	- - - - -	—————	~~~~~	nn nn →	■	○	┌

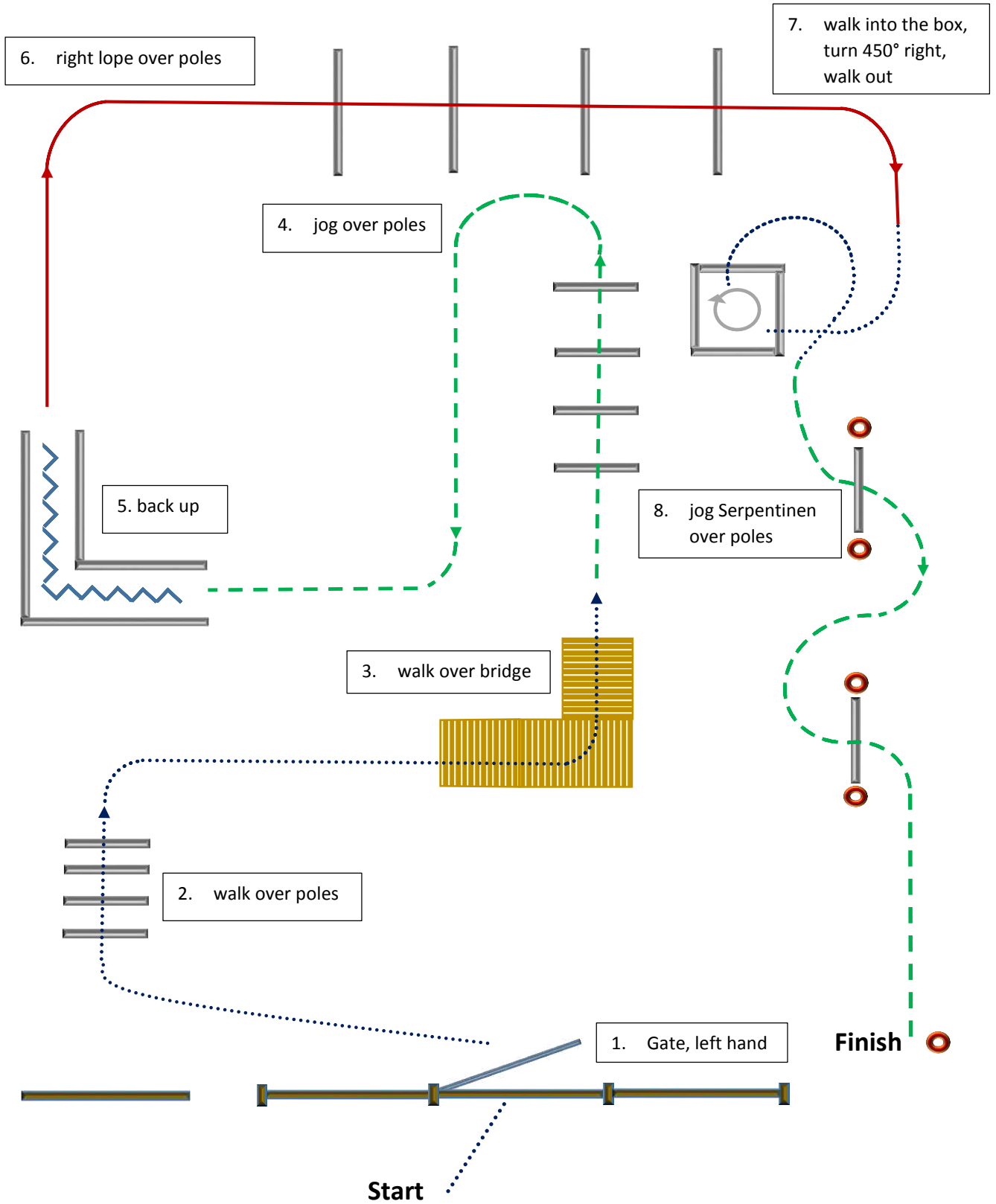

Walk/Schritt	Jog/Trab	Lope/Galopp	Back up/Rückwärts	Sidepass/Seitwärts	Galoppwechsel	Marker	erhöhte Stange
.....	- - - - -	—————	~~~~~	↔	—	○	⌋

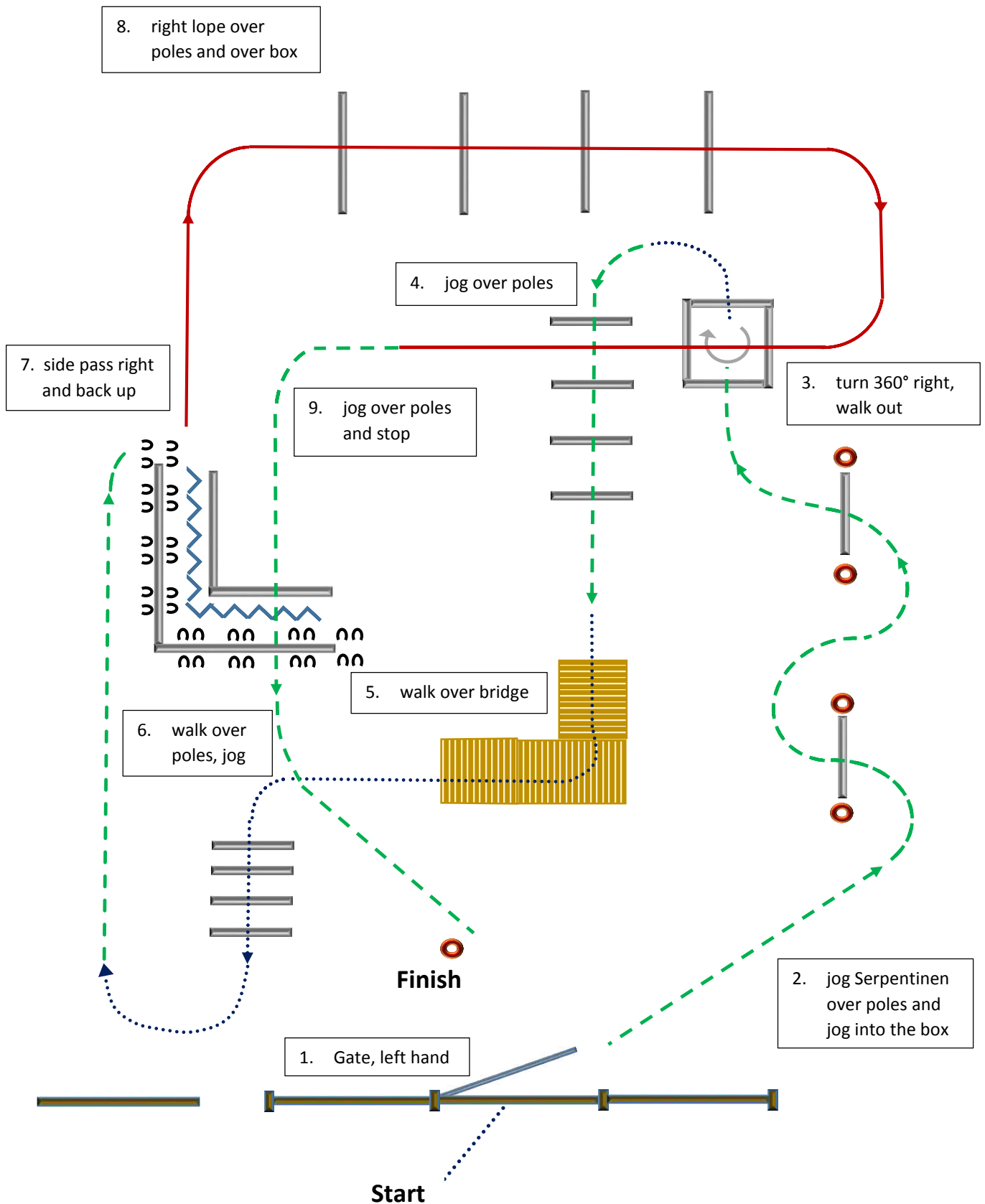

Walk/Schritt	Jog/Trab	Lope/Galopp	Back up/Rückwärts	Sidepass/Seitwärts	Galoppwechsel	Marker	erhöhte Stange
.....	- - - - -	—————	~~~~~	nn nn →	—	○	⌋

TRAIL OPEN/M

Trailparcours by M. Hexmann

Westernman.at



REINTAL RANCH

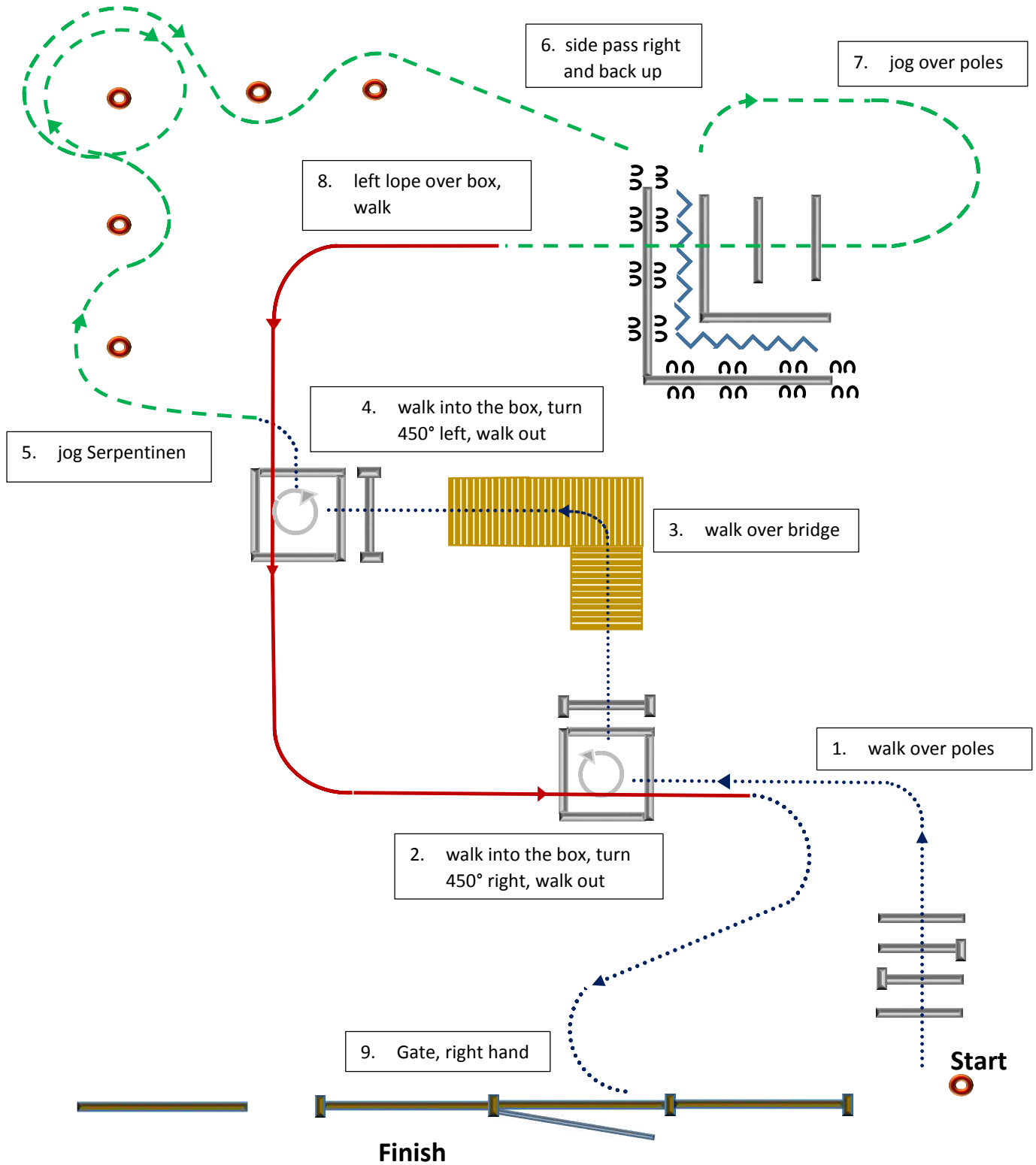

Walk/Schritt	Jog/Trab	Lope/Galopp	Back up/Rückwärts	Sidepass/Seitwärts	Galoppwechsel	Marker	erhöhte Stange
.....	- - - - -	—————	~~~~~	nn nn →	—	○	⌊

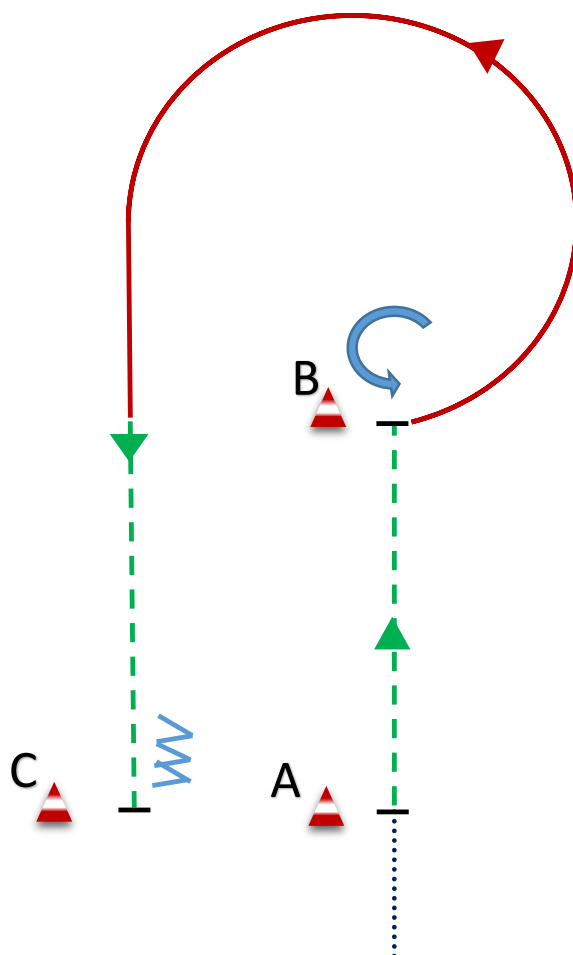

Aufstellung

	walk/Schritt	1. Trab A zu B
	jog/Trab	2. Stop bei B, 270° links
	extended trot/verstärkter Trab	3. Linksgaloppzirkel zu B
	lope/Galopp	4. Trab B zu A
	back/Rückwärts	5. Stop bei A, 3 Tritte zurück
	Galoppwechsel	
	sidepass/Seitwärts	

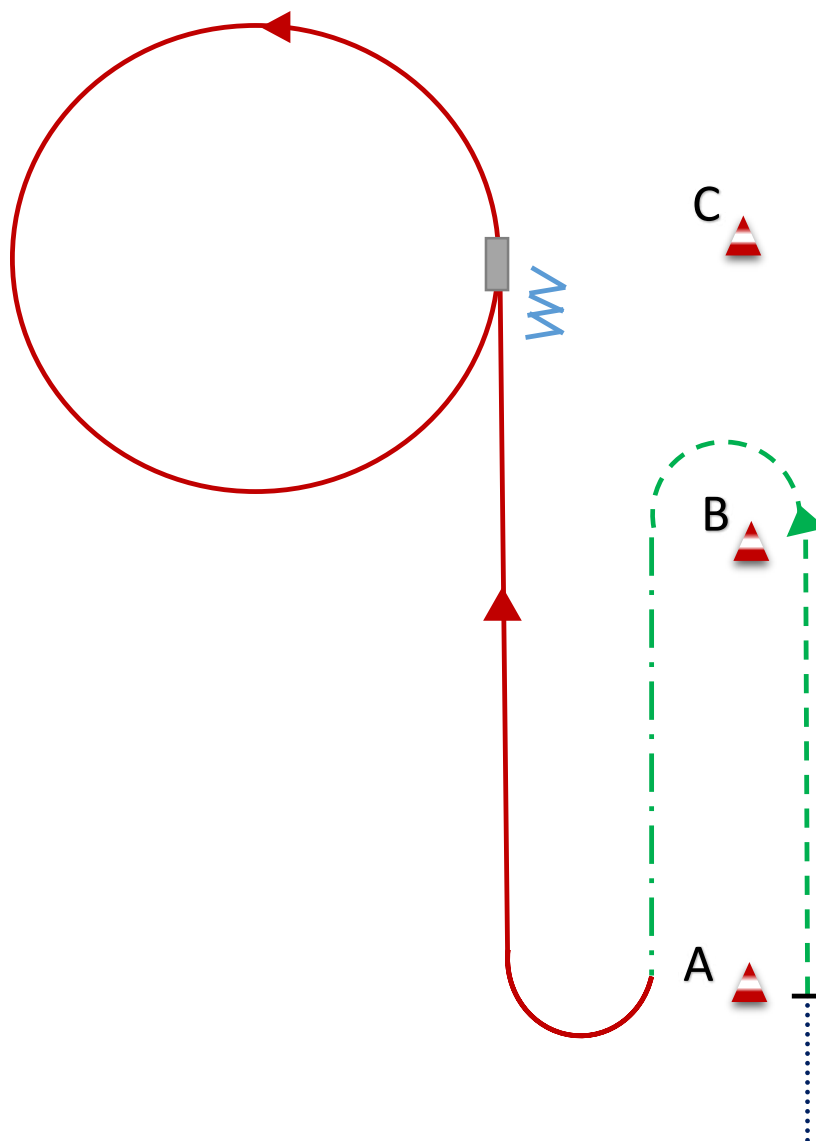

Aufstellung

	walk/Schritt	1. Trab A zu B
	jog/Trab	2. Verstärkter Trab B zu A
	extended trot/verstärkter Trab	3. Rechtsgalopp A zu C
	lope/Galopp	4. C einfacher/fliegender Galoppwechsel
	back/Rückwärts	5. Linksgaloppzirkel
	Galoppwechsel	6. Stop bei C
	sidepass/Seitwärts	7. 5 Tritte zurück

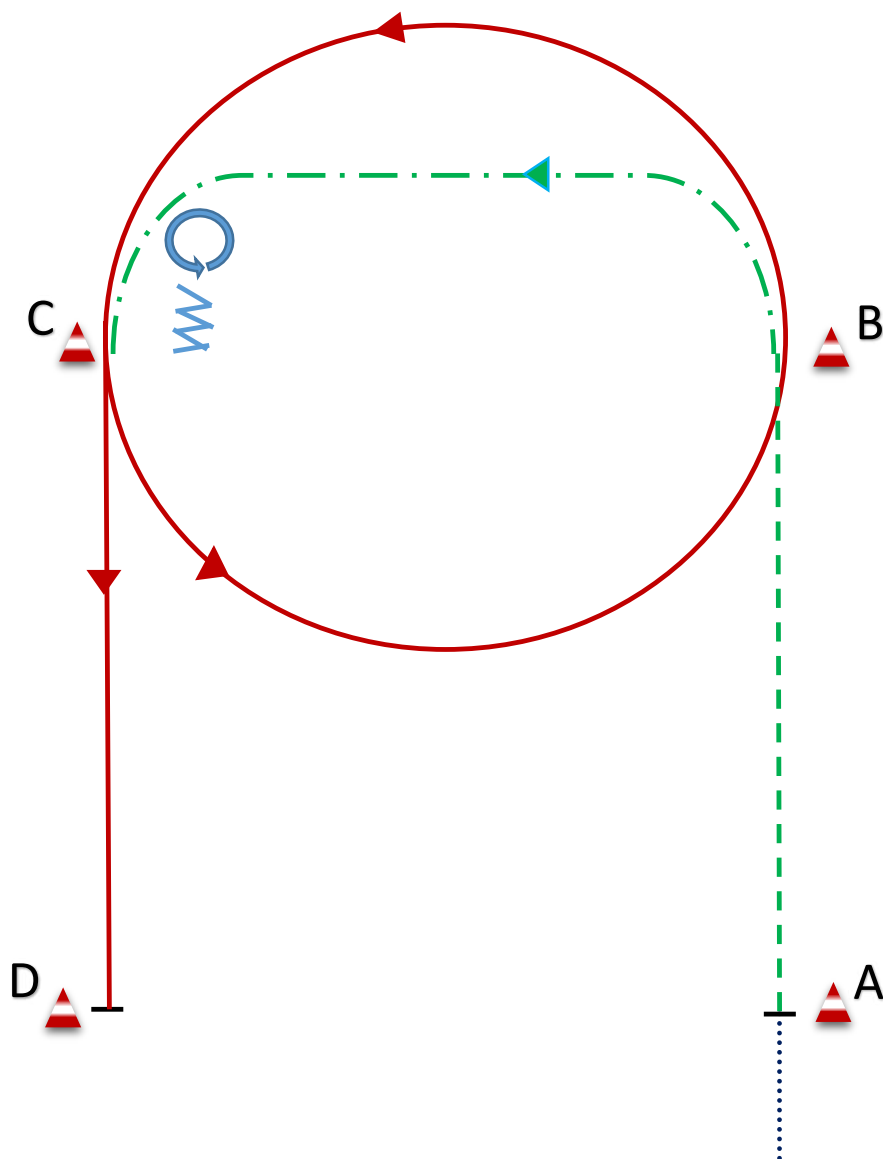

Aufstellung

	walk/Schritt	1. Trab A zu B
	jog/Trab	2. Verstärkter Trab B zu C
	extended trot/verstärkter Trab	3. Stop bei C , 5 Schritte zurück, 360° links
	lope/Galopp	4. Linksgalopp C zu B
	back/Rückwärts	5. Linksgalopp speed B zu C
	Galoppwechsel	6. Linksgalopp C zu D
	sidepass/Seitwärts	7. Stop bei D

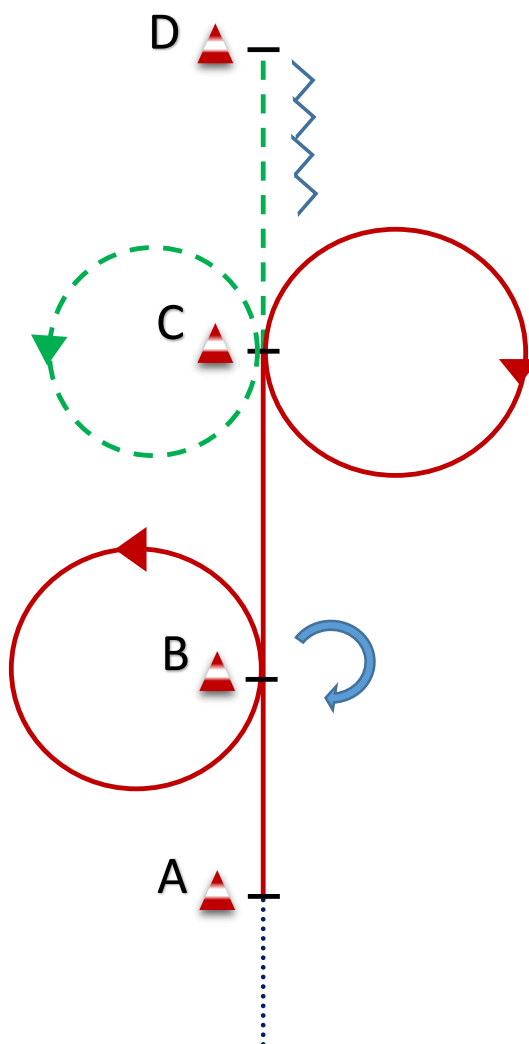

Aufstellung

	walk/Schritt	1. A zu B Linksgalopp, bei B Linksgaloppzirkel
	jog/Trab	2. bei B Stop, 360° Wendung rechts
	extended trot/verstärkter Trab	3. Rechtsgalopp B bis C, bei C Rechtsgaloppzirkel
	lope/Galopp	4. bei C Trabzirkel nach links, C bis D Trab
	back/Rückwärts	5. bei D Stop, 6 Tritte rückwärts
	Galoppwechsel	
	sidepass/Seitwärts	